

# ECONseries

## Economy USB

### Mini-Instruments

#### ■ Flexible Yet Economical

- A variety of low-cost ECONseries modules are available to provide flexible yet economical solutions.
- Choose the number of analog I/O and digital I/O channels, the resolution you need, and the signal range of your application.

#### ■ Easy Plug-and-Play Measurements

- Connect the module to the USB 2.0 or 1.1 port of your PC.
- Attach signals directly to screw terminals on the module.
- Run multiple subsystem operations simultaneously.
- No power supply needed.

#### ■ Oscilloscope Function

- Stream, plot, and analyze data from up to eight analog input channels.
- Scroll, pan, zoom, or freeze live signals.
- Select the trigger type, level, and channel.
- Print or save your data to an Excel file.

#### ■ Chart Recorder Function

- Record up to 32,000 data points from up to eight analog input channels.
- Log data to an Excel file.

#### ■ Digital Voltmeter Function

- Measure data from up to eight analog input channels and view it in a 5-digit digital display.
- Display the maximum or true root mean square (RMS) value.

#### ■ File Viewer Function

- Load a previously saved Excel file.
- Scroll, zoom, pan, or print your data.



The GO! Application allows instant out-of-the-box measurements with standard instrument-like displays

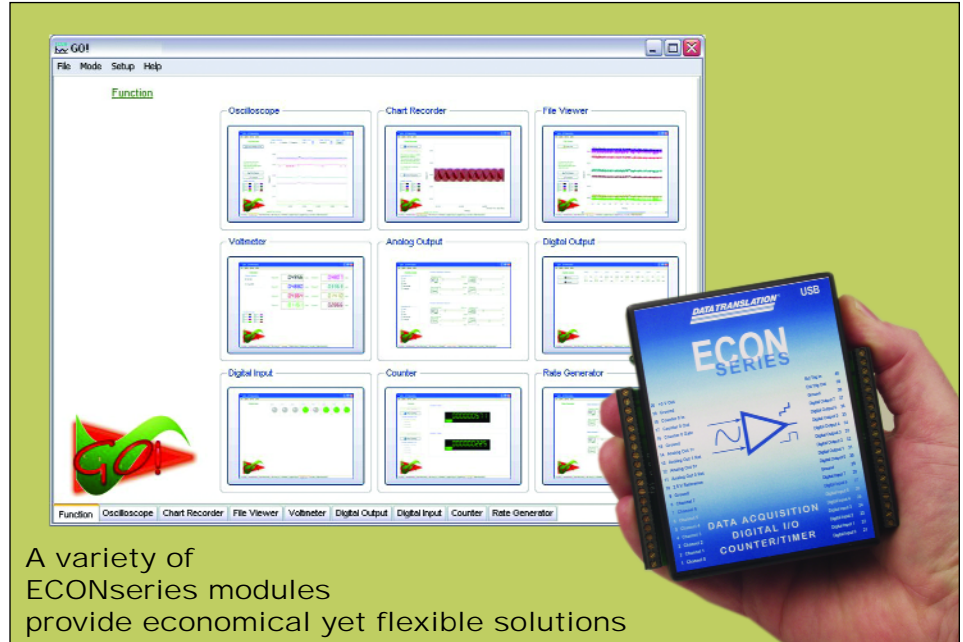

A variety of ECONseries modules provide economical yet flexible solutions

**Figure 1.** The ECONseries features the powerful GO! application to provide economical, multifunction data acquisition instruments for the USB bus. Simply install the software, connect your module to any USB port, and GO!

#### ■ Waveform Generation

- Generate DC, sine, rectangle, or triangle, waveforms from two analog output channels.
- Select the frequency, amplitude, offset and duty cycle of your signal.

#### ■ Digital I/O Control

- Monitor the status of up to 28 digital inputs using LEDs.
- Control the state of up to 28 digital outputs using switches.

#### ■ External Event Counting

- Count pulses from the counter/timer for 1, 2, or 5 seconds or for an unlimited time.

#### ■ Rate Generation

- Control the frequency of a continuous pulse output signal from the counter/timer.

### ECONseries Modules

Modules	Type	Analog Inputs	Input Range	Analog Outputs	Resolution	Throughput	DIO Rate	C/Ts Lines
DT9812-10V	DAQ	8 SE	+/- 10 V	2	12-bit	40 kHz	8 in/8 out	1
DT9812-2.5V	DAQ	8 SE	0-2.5 V	2	12-bit	40 kHz	8 in/8 out	1
DT9810	DAQ	8 SE	0-2.44 V	—	10-bit	25 kHz	20 I/O	1
DT9817	DIO	—	—	—	—	—	28 I/O	1



**Figure 2.** Connect to a host computer using the standard USB 1.1 or 2.0 plug-in connector on the ECONseries module. The USB connector provides power to the module, eliminating the need for an external power supply, while providing complete enumeration for all data flow.

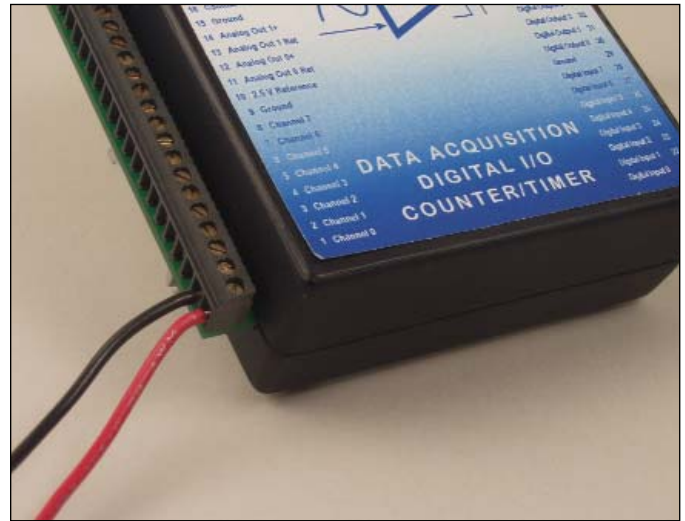

**Figure 3.** Connect sensors directly to the screw terminal of the module. Screw terminals can accept AWG 26 to AWG 16 size wire.

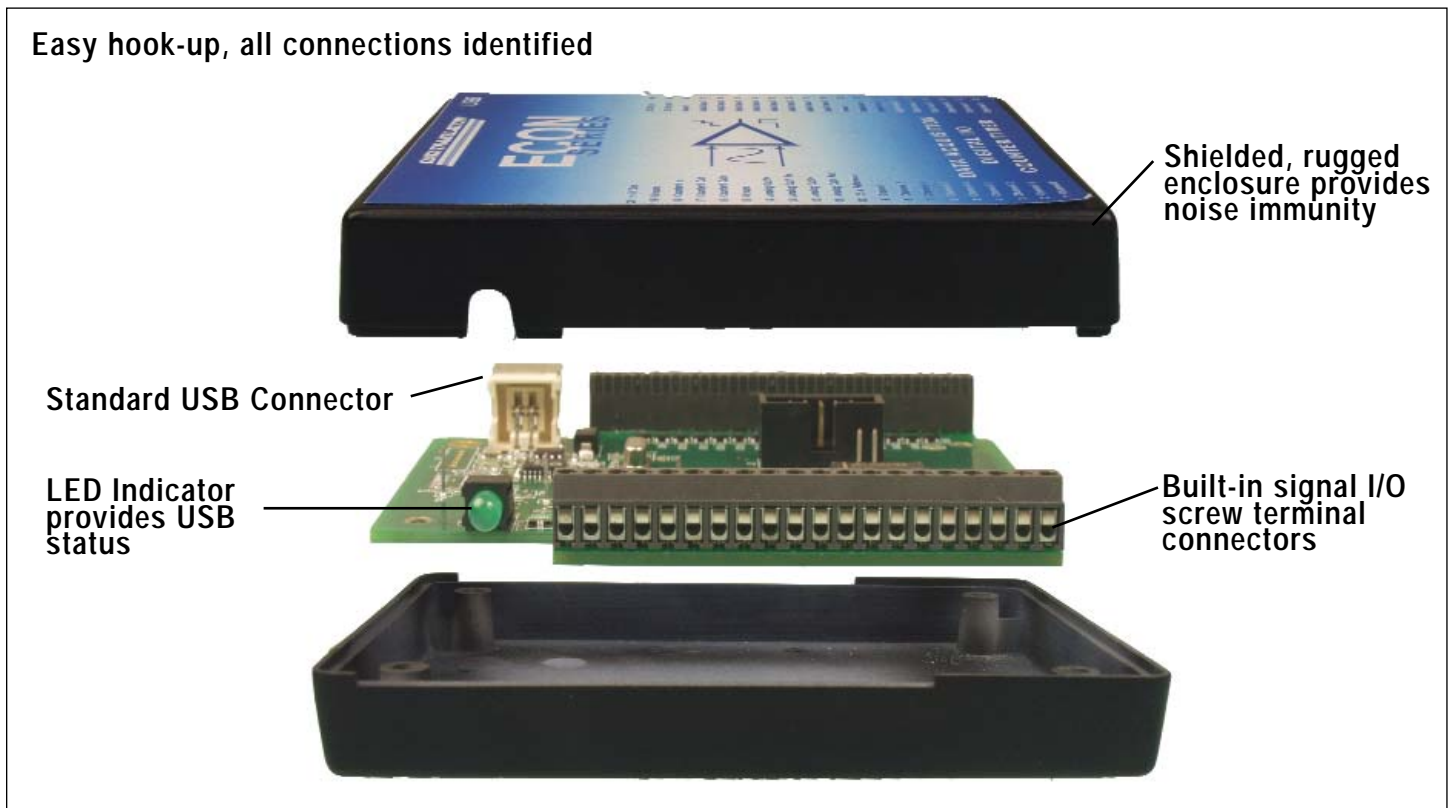

**Figure 4.** ECONseries modules provide easy signal and USB connections in a shielded, rugged enclosure.

# The ECONseries design provides the following major advantages:

## 1. Prevents Measurement Errors

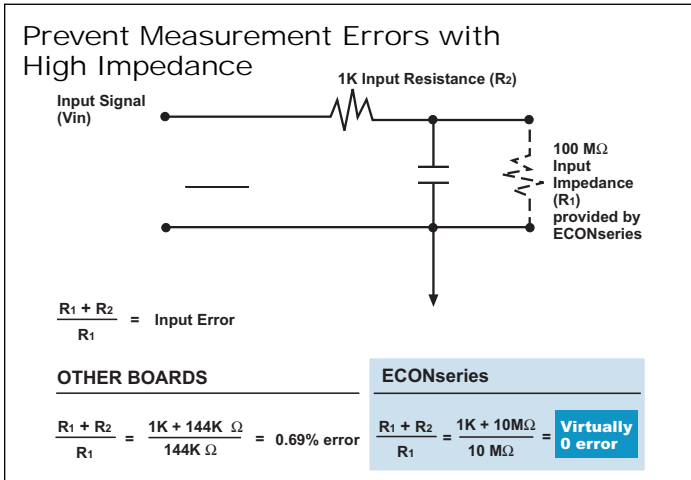

**Figure 5.** The ECONseries provides 10 MOhms of input impedance for virtually error-free analog input measurements.

## 2. Operates Reliably

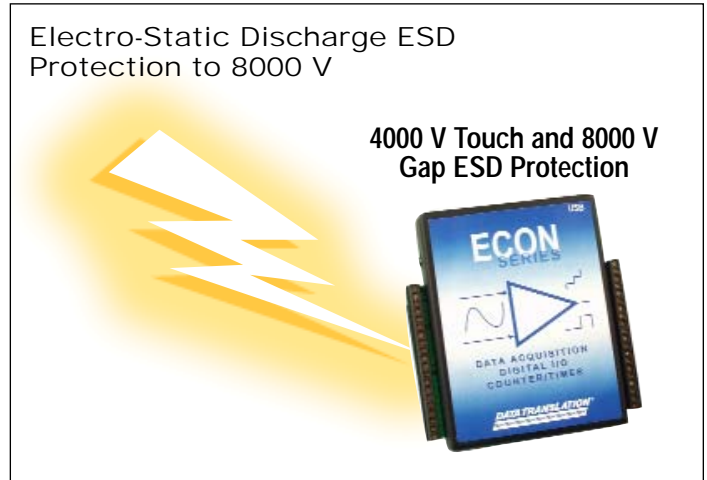

**Figure 6.** The ECONseries provides 4000 V touch and 8000 V gap ESD protection circuitry for superior noise immunity.

## 3. Performs Simultaneous Operations

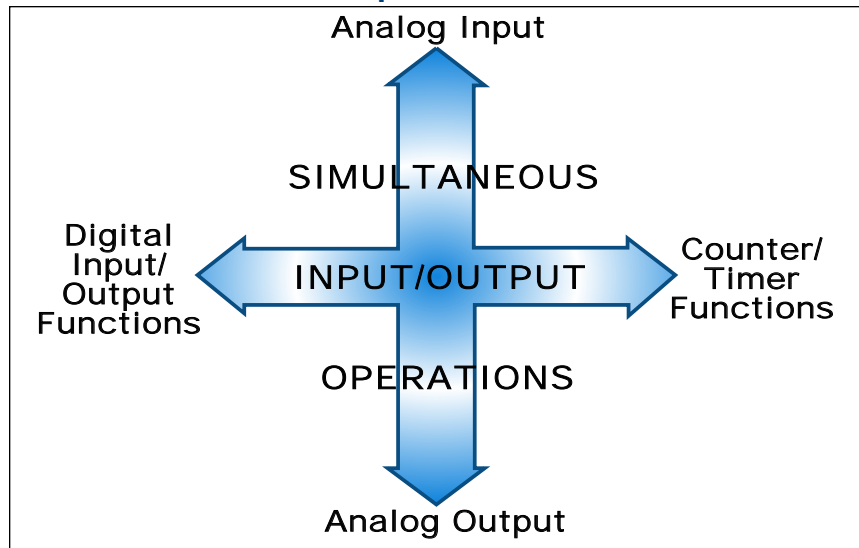

**Figure 7.** The ECONseries supports simultaneous subsystem operations - great for measurement and control application.

## 4. Generates Waveforms at up to 40 kHz

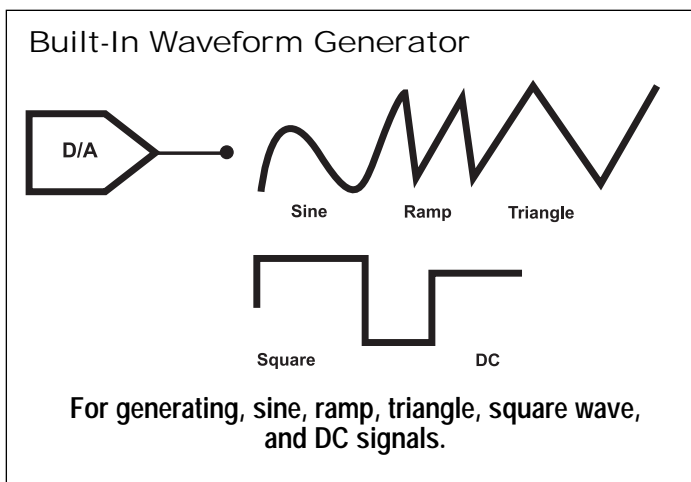

**Figure 8.** The DT9812-2.5 V and the DT9812-10V modules provide 2 waveform DACs for generating sine, ramp, triangle, square wave, and DC signals.

## 5. Detects Edges for Pulse Width, Frequency, & Period Measurements

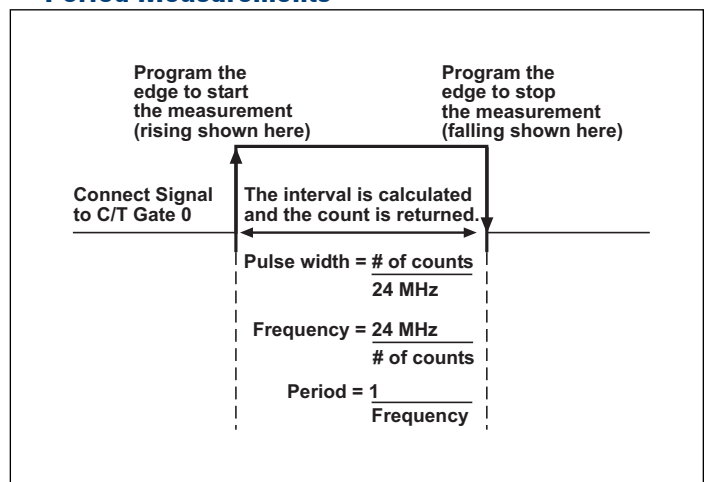

**Figure 9.** Programmable edges allow you to use the counter/timer of an ECONseries module to measure the pulse width, frequency, and period of a signal.

## Overview

The ECONseries features the powerful GO! application to provide economical, multifunction instruments for the USB bus. Simply install the software, connect your module to any USB port, and GO!

ECONseries modules are available in a number of configurations to offer the maximum flexibility - select the number of analog and digital I/O channels, the resolution you need, and the signal range required by your application.

## GO! Application

For measurements right out of the box, use the GO! application. The GO! application automatically detects and configures the module you are using, and provides the following standard instrument-like displays for data acquisition, control, and display:

- Oscilloscope - Stream, plot, and analyze data from up to eight analog input channels. The software automatically adjusts for resolution and input signal range. You can scroll, pan, zoom, or freeze live signals; select the trigger type, level, and channel; and print or save

your data to an Excel file.

- Chart Recorder - View and record up to 32,000 data points from eight analog input channels. Data is logged to an Excel file.
- Voltmeter - Measure and view data from up to eight analog input channels with a 5-digit digital display. You can choose to display the maximum or true root mean square (RMS) value.
- File Viewer - Load a previously saved Excel file. You can scroll, zoom, pan, or print your data.
- Waveform Generation - Generate DC, sine, rectangle, triangle waveforms from one or both analog output channels. You can select the duty cycle, frequency, amplitude, and offset of the signal.
- Digital Input - Monitor the status of up to 28 digital inputs using LEDs.
- Digital Output - Control the state of up to 28 digital output lines using switches.
- Counter - Count pulses from the counter/timer for 1, 2, or 5 seconds or for an unlimited time and view the count in a 9-digit digital display.
- Rate Generator - Control the frequency and duty cycle of a continuous pulse output signal from the counter/timer.

## Analog Inputs

The DT9810, DT9812 2.5V, and DT9812-10V modules provide 8 multiplexed single-ended analog input channels.

The DT9810 provides 10-bit resolution and a sampling frequency of up to 25 kHz, while the DT9812-2.5V and DT9812-10V provide 12-bit resolution and a sampling frequency of up to 40 kHz.

DT9810 modules provide a full scale input range of 0 to 2.44 V and DT9812-2.5V modules feature a full-scale input signal range of 0 to 2.5 V. If you need a full-scale input signal range of +/- 10 V, the DT9812-10V is available.

Both the DT9812-2.5V and DT9812-10V provide programmable gains of 1, 2, 4, and 8 to support a variety of input ranges.

**Effective Input Ranges**

Gain	DT9812-2.5V	DT9812-10V
1	0 to 2.5 V	±10 V
2	0 to 1.25 V	±5 V
4	0 to 0.625 V	±2.5 V
8	0 to 0.3125 V	±1.25 V

Note: The GO! Application uses a gain of 1. Gains of 2, 4, and 8 are supported at the driver level.

## Oscilloscope

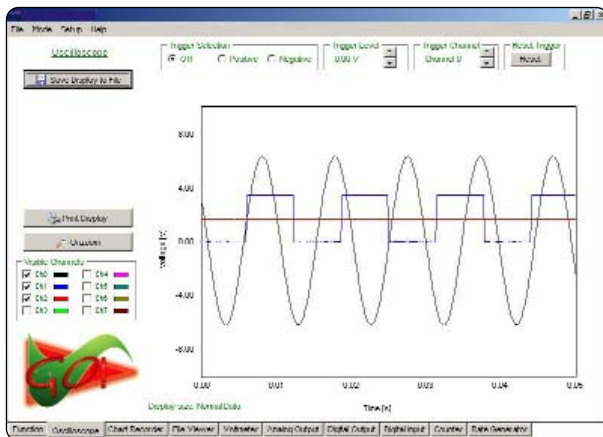

**Figure 10.** Use the Oscilloscope tab of the GO! application to stream, plot, and analyze data from up to eight single-ended analog input channels. The software automatically adjusts for resolution and input signal range. You can scroll, pan, zoom, or freeze live signals; select the trigger type, level, and channel; and print or save your data to an Excel file.

## Chart Recorder

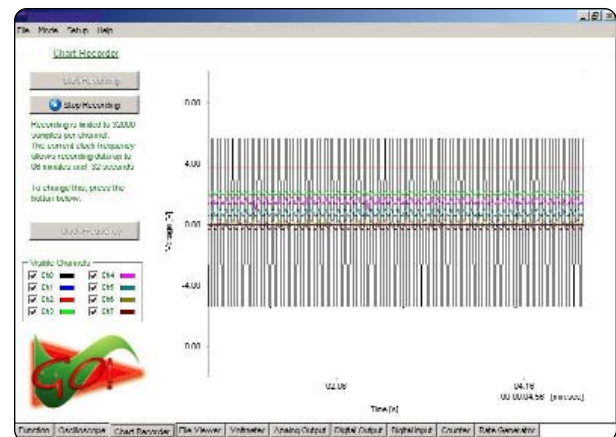

**Figure 11.** Use the Chart Recorder tab of the GO! application to view and record up to 32,000 data points from up to eight single-ended analog input channels. Data is logged to an Excel file.

**Voltmeter**

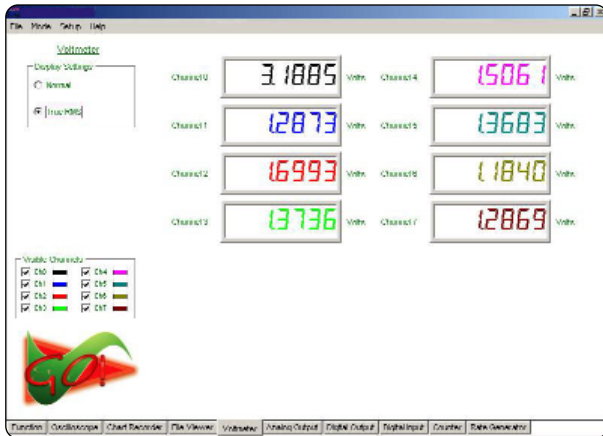

**Figure 12.** Use the Voltmeter tab of the GO! application to measure and view data from up to eight analog input channels in a 5-digit digital display. You can choose to display the maximum or RMS value.

The GO! application provides the Oscilloscope (Figure 10), Chart Recorder (Figure 11), Voltmeter (Figure 12), and File Viewer (Figure 13) instrument-like displays to acquire, view, print, and save data from all eight on the ECONseries modules.

**Waveform Generation**

The DT9812-2.5V module provides 2, 12-bit waveform analog output channels with an output signal range of 0 to 2.5 V. The DT9812-10V module provides 2, 12-bit analog output channels with an output signal range of +/- 10 V. Both modules support an update rate of up to 40 kS/s.

Use the Waveform Generator display of the GO! application (Figure 6) to generate sine, rectangle, triangle, or DC waveforms from one or both analog output channels. You can select the frequency, amplitude, duty, and offset cycle of the signal.

Simultaneous analog input and analog output operations are supported at the driver level.

**Digital I/O Lines**

The DT9812-2.5V and the DT9812-10V modules feature 8 digital input lines and 8 digital output lines. The DT9810 module provides 20 programmable digital I/O lines. If you need more digital I/O lines and do not

**File Viewer**

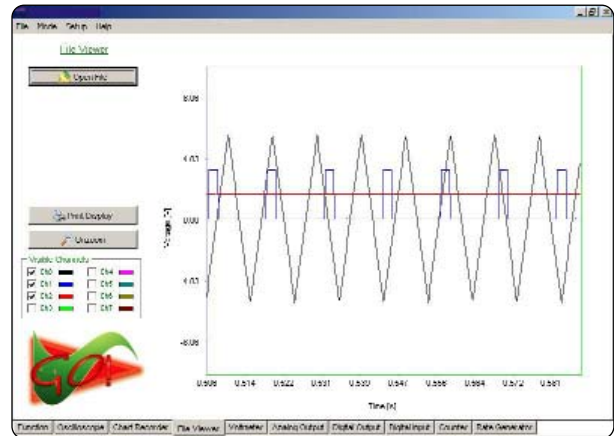

**Figure 13.** Use the File Viewer tab of the GO! application to load a previously saved Excel file. You can scroll, zoom, pan, or print your data.

need analog I/O functionality, select the DT9817 module, which provides 28 programmable digital I/O lines.

Use the Digital Input or Digital Output display of the GO! application (Figure 15 & 16) to monitor and control the digital I/O lines.

**Multifunction Counter/Timers**

All modules feature 1, 16-bit user counter/timer channel, allowing you to perform event counting, frequency measurement, and continuous pulse output operations.

Use the Counter display of the GO! application (Figure 17) to count pulses from the counter/timer or the Rate Generator display (Figure 18) to

**Waveform Generator**

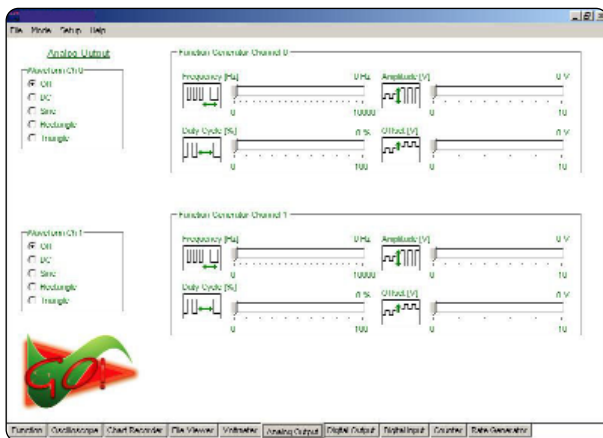

**Figure 14.** Use the Waveform Generator tab of the GO! application to generate DC, sine, rectangle, triangle waveforms from one or both analog output channels. You can select the duty cycle, frequency, amplitude, and offset of the signal.

**Digital Input**

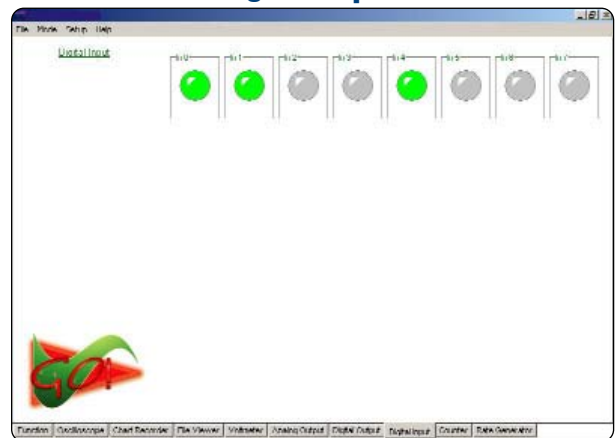

**Figure 15.** Use the Digital Input tab of the GO! application to monitor the status of the digital inputs using LEDs. The GO! application supports up to 16 digital inputs.

## Digital Output

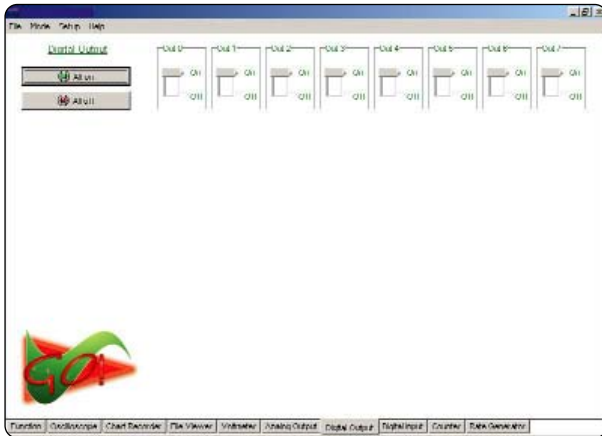

**Figure 16.** Use the Digital Output tab of the GO! application to control the state of the digital output lines using switches. The GO! application supports up to 12 digital outputs.

## Counter

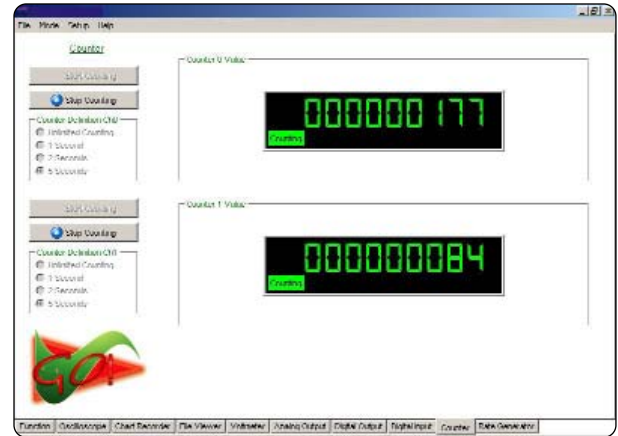

**Figure 17.** Use the Counter tab of the GO! application to count pulses from the counter/timer for 1, 2, or 5 seconds or for an unlimited time and view the count in a 9-digit display.

## Rate Generator

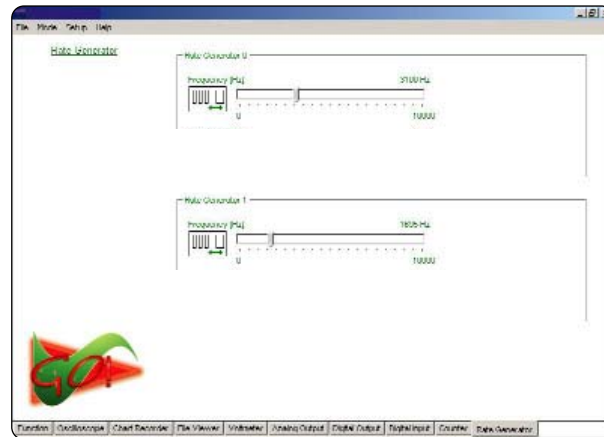

**Figure 18.** Use the Rate Generator tab of the GO! application to control the frequency of a continuous pulse output signal from the counter/timer.

generate a pulse output signal.

Programmable gates, clocks, and output signals are also supported at the driver level for maximum flexibility. In addition, programmable edges allow you to measure the time between two edges of a signal to determine the pulse width, frequency, or period of a signal.

### Flexible Clocks and Triggers

The DT9810, DT9812-2.5V, and DT9812-10V modules support an internal trigger and internal clock. In addition, the DT9812-2.5V and DT9812-10V modules support an external trigger and clock.

Use the internal trigger to start an analog input operation based

on a software command, or use the external trigger to start an analog input operation based on an external event.

Use the external clock signal to pace an analog input operation at a rate not available with the internal clock or when you want to pace at uneven intervals.

### Synchronizing Multiple Modules

You can synchronize the analog input operations of multiple DT9812-2.5V or DT9812-10V modules by connecting the output of the counter/ timer from one module to the clock input of the next module as shown in Figure 19.

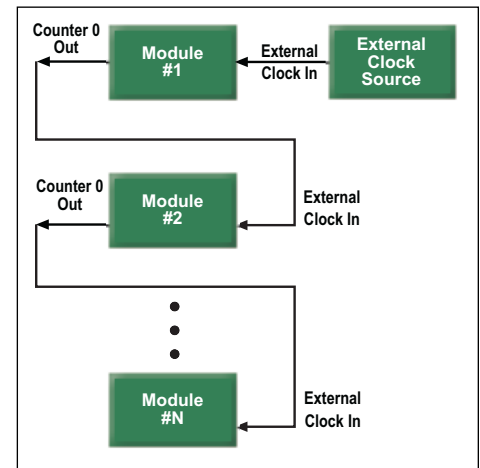

**Figure 19.** You can synchronize the analog I/O operations of multiple modules by connecting them together.

**Easy Signal Connections**

Screw terminals on the module allow easy and direct signal con-

nections. No extra accessories are required! Simply wire your signals to the module and you're all set.

And, because of the module's high impedance, measurement errors are prevented.

**DT9812-2.5V & DT9812-10V  
Pin Assignments**

**DT9812-2.5V & DT9812-10V  
Screw Terminal Assignments**

Screw	Signal Terminal	Screw	Signal Terminal
20	USB +5 V Out	40	Ext Trig In
19	Ground	39	Ext Clock In
18	Counter 0 In	38	Ground
17	Counter 0 Out	37	Digital Output 7
16	Counter 0 Gate	36	Digital Output 6
15	Ground	35	Digital Output 5
14	DAC 1	34	Digital Output 4
13	DAC 1 Return	33	Digital Output 3
12	DAC 0	32	Digital Output 2
11	DAC 0 Return	31	Digital Output 1
10	2.5 V Reference	30	Digital Output 0
9	Analog Ground	29	Ground
8	Analog In Ch 7 High	28	Digital Input 7
7	Analog In Ch 6 High	27	Digital Input 6
6	Analog In Ch 5 High	26	Digital Input 5
5	Analog In Ch 4 High	25	Digital Input 4
4	Analog In Ch 3 High	24	Digital Input 3
3	Analog In Ch 2 High	23	Digital Input 2
2	Analog In Ch 1 High	22	Digital Input 1
1	Analog In Ch 0 High	21	Digital Input 0

**DT9812-2.5V & DT9812-10V  
Block Diagram**

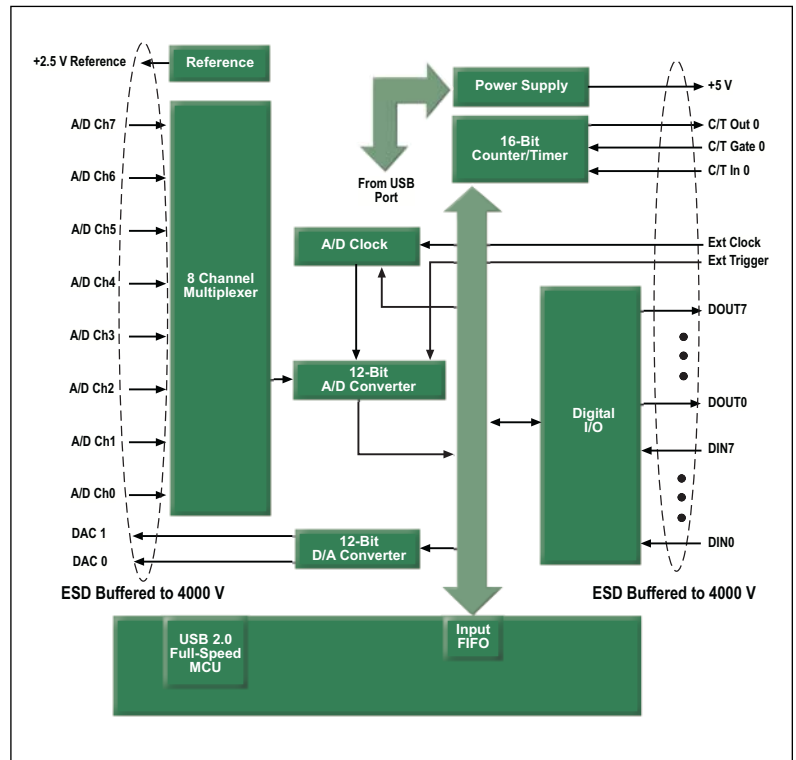

**Figure 20.** This block diagram shows all the functional signals of the DT9812-2.5V and DT9812-10V USB modules for performing analog I/O, digital I/O, and counter/timer operations.

## DT9810 Pin Assignments

### DT9810 Screw Terminal Assignments

Screw	Signal Terminal	Screw	Signal Terminal
20	USB +5 V Out	40	Reserved
19	Ground	39	Reserved
18	Counter 0 In	38	Ground
17	Counter 0 Out	37	Digital I/O 15
16	Counter 0 Gate	36	Digital I/O 14
15	Ground	35	Digital I/O 13
14	Digital I/O 19	34	Digital I/O 12
13	Digital I/O 18	33	Digital I/O 11
12	Digital I/O 17	32	Digital I/O 10
11	Digital I/O 16	31	Digital I/O 9
10	2.44 V Reference	30	Digital I/O 8
9	Analog Ground	29	Ground
8	Analog In Ch 7 High	28	Digital I/O 7
7	Analog In Ch 6 High	27	Digital I/O 6
6	Analog In Ch 5 High	26	Digital I/O 5
5	Analog In Ch 4 High	25	Digital I/O 4
4	Analog In Ch 3 High	24	Digital I/O 3
3	Analog In Ch 2 High	23	Digital I/O 2
2	Analog In Ch 1 High	22	Digital I/O 1
1	Analog In Ch 0 High	21	Digital I/O 0

## DT9810 Block Diagram

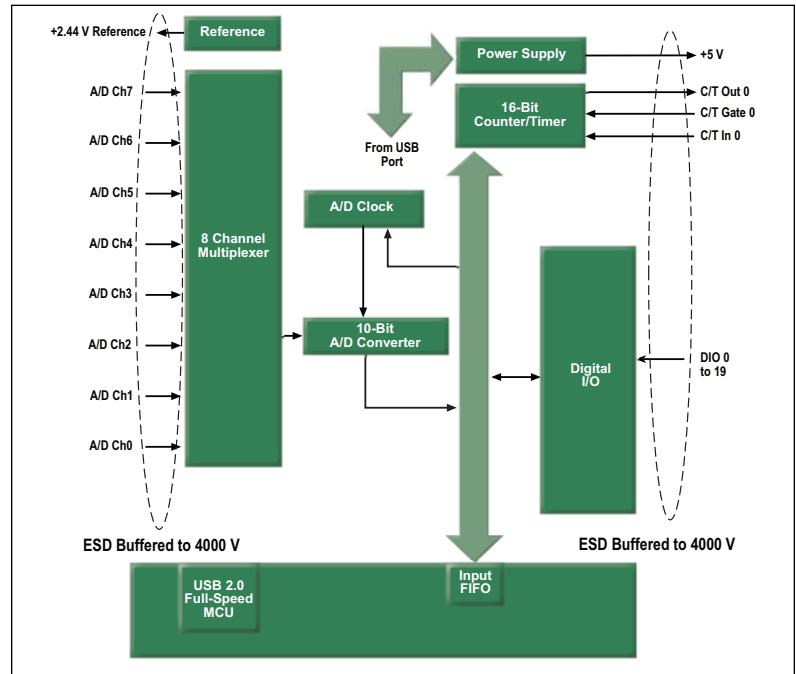

**Figure 21.** This block diagram shows all the functional signals of the DT9810 USB module for performing analog input, digital I/O, and counter/timer operations.

## DT9817 Pin Assignments

### DT9817 Screw Terminal Assignments

Screw	Signal Terminal	Screw	Signal Terminal
20	USB +5 V Out	40	Reserved
19	Ground	39	Reserved
18	Counter 0 In	38	Ground
17	Counter 0 Out	37	Digital I/O 15
16	Counter 0 Gate	36	Digital I/O 14
15	Ground	35	Digital I/O 13
14	Digital I/O 27	34	Digital I/O 12
13	Digital I/O 26	33	Digital I/O 11
12	Digital I/O 25	32	Digital I/O 10
11	Digital I/O 24	31	Digital I/O 9
10	Reserved	30	Digital I/O 8
9	Reserved	29	Ground
8	Digital I/O 23	28	Digital I/O 7
7	Digital I/O 22	27	Digital I/O 6
6	Digital I/O 21	26	Digital I/O 5
5	Digital I/O 20	25	Digital I/O 4
4	Digital I/O 19	24	Digital I/O 3
3	Digital I/O 18	23	Digital I/O 2
2	Digital I/O 17	22	Digital I/O 1
1	Digital I/O 16	21	Digital I/O 0

## DT9817 Block Diagram

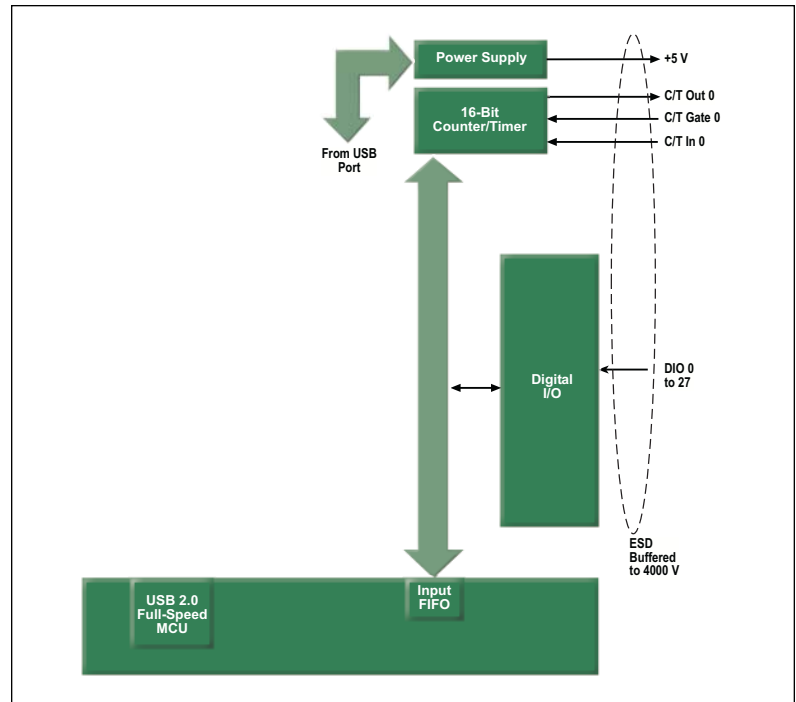

**Figure 22.** This block diagram shows all the functional signals of the DT9817 USB module for performing digital I/O and counter/timer operations.

**A/D Subsystem Specifications**

Feature	DT9810 Specifications	DT9812-2.5V Specifications	DT9812-10V Specifications
Number of analog input channels	8 single-ended	8 single-ended	8 single-ended
Number of gains	—	4 (1,2,4,8)	4 (1,2,4,8)
Resolution	10-bit	12-bit	12-bit
Data encoding	binary	binary	offset binary
System accuracy, to % of FSR			
Gain = 1:	0.1%	0.03%	0.03%
Gain = 2:	—	0.04%	0.04%
Gain = 4:	—	0.05%	0.05%
Gain = 8:	—	0.06%	0.10%
Range	0 to 2.44 V	0 to 2.5 V, 0 to 1.25 V, 0 to 0.625 V, 0 to 0.3125 V	±10 V, ±5 V, ±2.5 V, ±1.25 V
Nonlinearity	0.1%	0.05%	0.05%
Differential nonlinearity	±1/2 LSB	±1/2 LSB	±1/2 LSB
Inherent quantizing error	1 LSB	1 LSB	1 LSB
Drift			
Zero:	±20 µV	±20 µV	±100 µV
Gain:	±50 ppm	±50 ppm	±50 ppm
Differential linearity:	monotonic	monotonic	monotonic
Input impedance <sup>1</sup>			
Off channel	10 MΩ, 10 pf	10 MΩ, 10 pf	10 MΩ, 10 pf
On channel:	10 MΩ, 100 pf	10 MΩ, 100 pf	10 MΩ, 100 pf
Input bias current	±10 nA	±10 nA	±10 nA
Maximum input voltage (without damage)			
Power on:	±35 V	±35 V	±35 V
Power off:	±20 V	±20 V	±20 V
A/D conversion time	10 µs	10 µs	10 µs
Channel acquisition time (±½ LSB)	10 µs	10 µs	10 µs
Sample-and-hold			
Aperture uncertainty:	2 ns	2 ns	2 ns
Aperture delay:	200 ns	200 ns	200 ns
Throughput	25 kHz	40 kHz	40 kHz
ESD protection (per spec)			
Arc:	8 kV	8 kV	8 kV
Contact:	4 kV	4 kV	4 kV
Reference	2.44 V	2.5 V	2.5 V
Monotonicity	Yes	Yes	Yes
Sample Clock			
Internal:	Yes	Yes	Yes
External:	No	Yes	Yes
Trigger Source			
Internal:	Yes	Yes	Yes
External:	No	Yes	Yes

<sup>1</sup> Very high input impedance minimizes any source error.

## D/A Subsystem Specifications

Feature	DT9812-2.5V Specifications	DT9812-10V Specifications
Number of waveform analog output channels	2	2
Resolution	12-bit	12-bit
Data encoding	Binary	Offset binary
Nonlinearity	0.05%	0.05%
Differential nonlinearity	± LSB	±1 LSB
Inherent quantizing error	1 LSB	1 LSB
Output range	0 to 2.5 V	±10 V
Error		
Zero:	±1 mV	±1 mV
Gain:	±0.1%	±0.1%
Drift		
Zero (bipolar):	±20 $\mu\text{V}/^\circ\text{C}$	±100 $\mu\text{V}/^\circ\text{C}$
Gain:	±50 ppm	±50 ppm
Throughput		
Waveform generation mode:	40 kHz	40 kHz
Continuously paced analog output mode:	40 kHz	40 kHz
FIFO <sup>1</sup>	2000	2000
Current output	±2 mA	±2 mA
Output impedance	<0.2 $\Omega$	<0.2 $\Omega$
Capacitive driver capability	1000 pF minimum	1000 pF minimum
Protection	Short to ground	Short to ground
Power-on voltage	0 V ±5 mV	0 V ±10 mV
Settling time to 0.01% of FSR	20 $\mu\text{s}$	20 $\mu\text{s}$
Slew rate	2 V / $\mu\text{s}$	2 V / $\mu\text{s}$
Glitch energy	1 $\mu\text{V}$ -sec	1 $\mu\text{V}$ -sec
ESD protection (per spec)		
Arc:	8 kV	8 kV
Contact:	4 kV	4 kV
Monotonicity	Yes	Yes
Output Clock		
Internal:	Yes	Yes
External:	No	No
Trigger Source		
Internal:	Yes	Yes
External:	No	No

<sup>1</sup> Total FIFO size used for both A/D and D/A on the module is 2K.

## DIN/DOUT Subsystem Specifications

Feature	DT9810 Specifications	DT9812-2.5V and DT9812-10V Specifications	DT9817 Specifications
Number of digital I/O lines	20 programmable	16 (8 in/8 out)	28 programmable
Number of ports	2, 8-bit and 1, 4-bit	2, 8-bit	3, 8-bit and 1, 4-bit
Input termination	No	No	No
Logic family	TTL	TTL	TTL
Logic sense	Positive true	Positive true	Positive true
Inputs			
Input type:	Level sensitive	Level sensitive	Level sensitive
Input logic load:	1 TTL Load	1 TTL Load	1 TTL Load
High input voltage:	2.4 V min	2.4 V min	2.4 V min
Low input voltage:	0.8 V max	0.8 V max	0.8 V max
Low input current:	-0.4 mA max	-0.4 mA max	-0.4 mA max
Outputs			
Fan out:	12 mA	12 mA	12 mA
High output:	2.8 V min	2.8 V min	2.8 V min
Low output:	0.6 V max	0.6 V max	0.6 V max
High output current (source):	2 mA	2 mA	2 mA
Low output current (sink):	12 mA	12 mA	12 mA
Software I/O selectable	Yes	No	Yes
ESD protection (per spec)			
Arc:	8 kV	8 kV	8 kV
Contact:	4 kV	4 kV	4 kV

**C/T Subsystem Specifications**

<b>Feature</b>	<b>Specifications</b>
Number of counter/timers	1
Resolution	16-bit
Counter/timer modes	Event counting, frequency measurement, edge-to-edge measurement, rate generation
Minimum pulse width (minimum amount of time it takes a C/T to recognize an input pulse)	200 ns
Logic family	TTL
Inputs	Level sensitive
Input logic load:	1 TTL Load
High input voltage:	2.4 V min
Low input voltage:	0.8 V max
Low input current:	-0.4 mA max
Outputs	
Fan out:	12 mA
High output:	2.8 V min
Low output:	0.6 V max
High output current (source):	2 mA
Low output current (sink):	12 mA
ESD protection (per spec)	
Arc:	8 kV
Contact:	4 kV
Internal clock frequency	24 MHz
Clock divider	4 to 65536

**External Trigger Specifications\***

<b>Feature</b>	<b>Specifications</b>
Trigger sources	
Internal:	Software initiated
External:	Software selectable
Input type	Edge sensitive
Logic family	TTL
Inputs	Level sensitive
Input logic load:	1 TTL Load
High input voltage:	2.4 V min
Low input voltage:	0.8 V max
Low input current:	-0.4 V mA max
Minimum pulse width	
High:	200 ns
Low:	200 ns
Triggering modes	
Single scan:	Yes
Continuous scan:	Yes
Triggered scan:	Yes

\* External trigger available on the DT9812-2.5V and DT9812-10V modules for analog input operations only.

## External Clock Specifications\*

Feature	Specifications
Input type:	Edge sensitive
Logic family:	TTL
Inputs:	
Input logic load:	Level sensitive
Input termination:	1 TTL Load
High input voltage:	2.4 V min
Low input voltage:	0.8 V max
Low input current:	-0.4 mA max
Oscillator frequency:	40 kHz max
Minimum pulse width	
High:	200 ns
Low:	200 ns

\* External clock available on the DT9812-2.5V and DT9812-10V modules for analog input operations only.

## Power, Physical, and Environmental Specifications

Feature	DT9810 and DT9817 Specifications	DT9812-2.5V Specifications	DT9812-10V Specifications
Power	<100 mA	<100 mA	<100 mA
+5 V Enumeration Operation	<100 mA	<100 mA	<250 mA
Physical			
Weight (board):	60.3 g	65.3 g	65.3 g
Weight (box with screw terminals and feet):	133.4 g	138.4 g	138.4 g
Physical			
Dimensions (board):	100 mm (L) x 100 mm (W) x 15.5 mm (H)		
Dimensions (box with screw terminals and feet):	107.7 mm (L) x 100 mm (W) x 33.5 mm (H)		
Environmental			
Operating temperature range:	0 to 70° C		
Storage temperature range:	-40° to 125° C		
Relative humidity:	to 95% non-condensing		

## Creating Custom Applications

The GO! application provides an easy-to-use solution for measuring signals right out of the box! If, you'd rather create your own application, the ECONseries is fully DT-Open Layers-compliant, allowing users of all levels - from programmers to application users - the ability to create a program for the ECONseries. The following software choices are provided free on the ECON CD:

- For nonprogrammers, **DT Measure Foundry** is a powerful visual software environment for creating test and measurement, control, and analysis applications. By dragging and dropping instrument-like components, called panels, on to your worksheet and configuring their property pages, you can develop powerful applications quickly. No programming or wiring is required!
- For Microsoft® Visual Basic and Visual C++ programmers, **DTx-EZ** provides ActiveX controls that allow quick and easy development of test and measurement applications.
- For LabVIEW programmers, **DT-LV Link** provides a collection of Virtual Instruments (VIs) that give you the ability to access the functions of the ECONseries modules through LabVIEW.
- The Data Acquisition Software Development Kit (**SDK**) is also available if you'd prefer to call API-level functions in Microsoft C to access DT-Open Layers features.

## Cross-Series Compatibility Saves Programming Time, Protects Your Investment

Virtually all Data Translation data acquisition boards, including the ECONseries, are compatible with the DT-Open Layers software standard. This means that if your application was developed with one of Data Translation's software products, you can easily upgrade to a new Data Translation board. Little or no programming is needed. For example, if you are currently using a DT300 board on a PCI bus, upgrading to a ECONseries module on the USB bus is simple - just load and configure the new driver and you're done.

## ECONseries User Manuals

Each ECONseries module includes a getting started and user's manual. Manuals are provided in electronic (PDF) format on the ECON CD that is shipped with the module. You can also purchase hard copies, if desired.

## Technical Support

Extensive information, including drivers, example code, pinouts, a searchable Knowledgebase, and much more, is available 24 hours a day on our web site at [www.datatranslation.com](http://www.datatranslation.com).

You can also contact Technical Support through email at [tsupport@datx.com](mailto:tsupport@datx.com) with any questions.

## Ordering Summary

### ECONseries Modules

- DT9812-10V
- DT9812-2.5V
- DT9810
- DT9817

### System Requirements

- Windows 2000/XP Professional Edition operating system.
- USB Ports - one or more (version 2.0 or 1.1).
- CD-ROM drives - one or more.

### Software

All software, including the GO! Application, is provided on the ECON CD that ships with module.